

#	Type	Color	H	B	Quantity
1	Phenolic 12		453	720	2
2	Phenolic 12		453	720	1
3	Phenolic 12		760	1760	1
4	Phenolic 3		114	842	4
5	Square profile 2 channel		-	1696	4
6	1/2" Round profile		-	842	8

Free Standing Bench 2'x4'

PROPRIETARY AND CONFIDENTIAL
 THE INFORMATION CONTAINED IN THIS DRAWING IS THE SOLE PROPERTY OF <INSERT COMPANY NAME HERE>. ANY REPRODUCTION IN PART OR AS A WHOLE WITHOUT THE WRITTEN PERMISSION OF <INSERT COMPANY NAME HERE> IS PROHIBITED.

		UNLESS OTHERWISE SPECIFIED:		NAME	DATE		
		DIMENSIONS ARE IN INCHES	DRAWN			TITLE: FREE STANDING BENCH 2'X4'	
		TOLERANCES:	CHECKED				
		FRACTIONAL ±	ENG APPR.				
		ANGULAR: MACH ± BEND ±	MFG APPR.				
		TWO PLACE DECIMAL ±	Q.A.				
		THREE PLACE DECIMAL ±	COMMENTS:			SIZE	DWG. NO.
		INTERPRET GEOMETRIC TOLERANCING PER:				A	REV
		MATERIAL				SCALE: 1:15	SHEET 1 OF 3
		FINISH					
NEXT ASSY	USED ON	APPLICATION	DO NOT SCALE DRAWING				

#1 720x453
(for CNC 724x455)

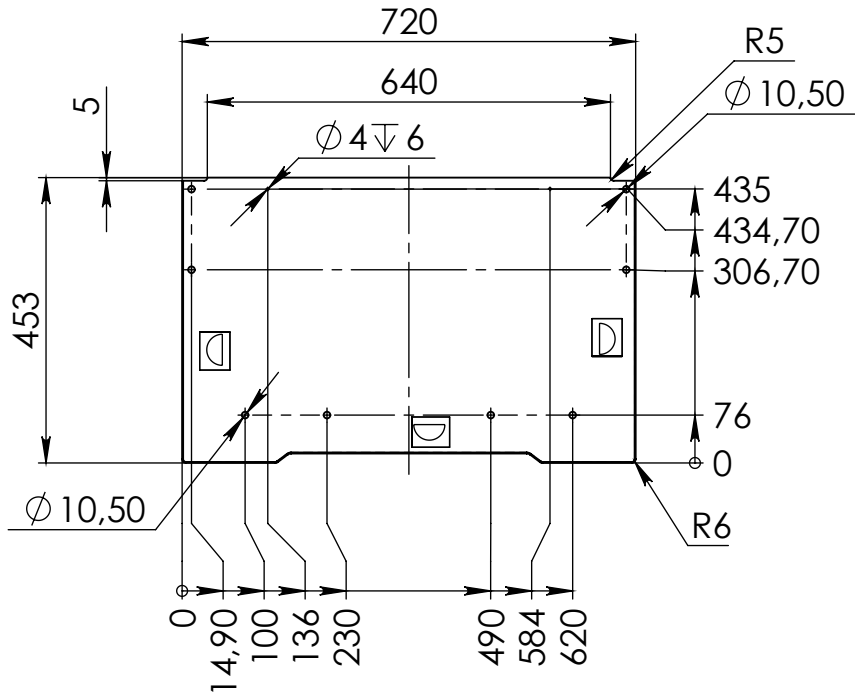

#2 720x453
(for CNC 724x455)

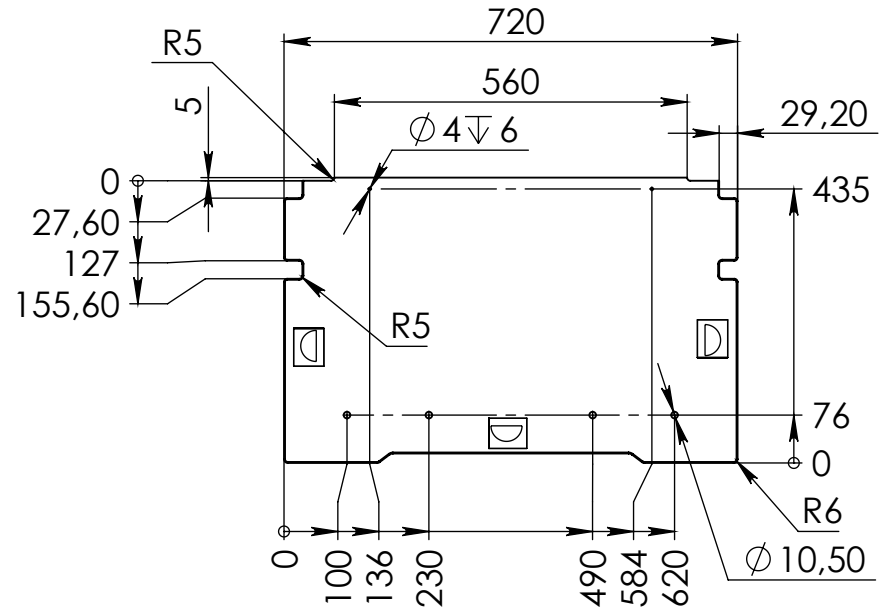

#5 1696

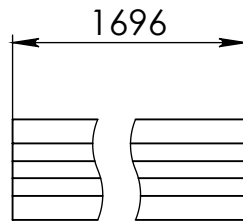

#6 842

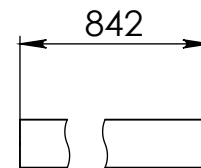

#3 1760x760
(for CNC 1764x764)

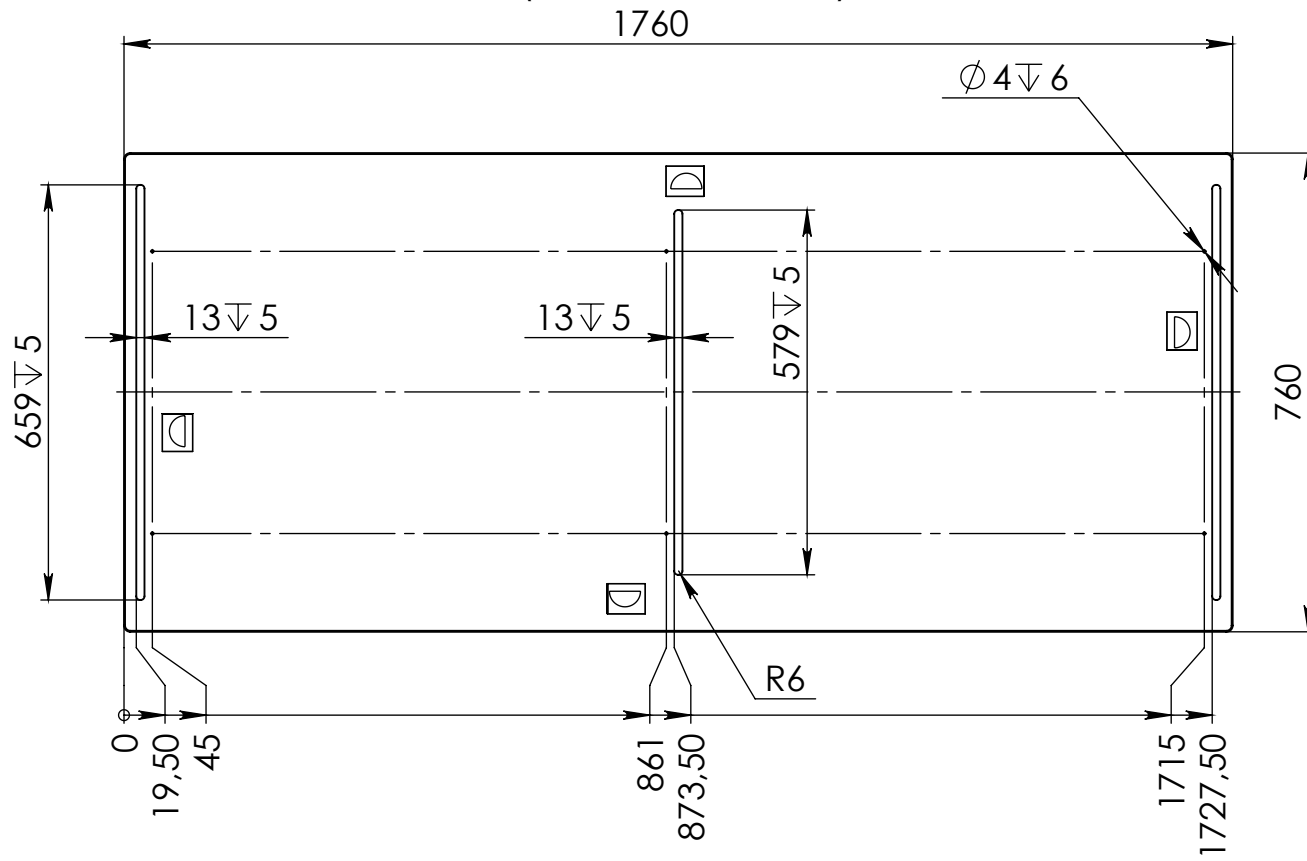

#4 114x842

